

●● LipoCollector® 3

User manual

In this world,
there is nothing
softer and thinner
than water. But to
compel the hard
and unyielding it
has no equal.“
(Laozi)



LipoCollector® 3

User manual



ISO 13485

Instructions on use and processing of the LipoCollector® 3, REF No. US670000

All rights reserved, particularly the right to reproduce and distribute as well as translate this user manual.

No part of this user manual may be reproduced in any form (by photocopying, microfilm or other methods) or processed, copied or distributed using electronic systems without prior written consent of Human Med.

The LipoCollector® 3 is a registered trademark owned by Human Med AG, Schwerin, Germany. The technology used in Human Med's products is protected by patents; further patents have been filed.

The information included in this user manual is subject to change or update without prior notification; and Human Med assumes no liability for the contents of the information.

Printed by: Human Med AG

Printed in Germany

Copyright © Human Med AG; Wilhelm-Hennemann-Straße 9, 19061 Schwerin; October 2015

Table of contents

1. Introduction	1-1
1.1. Symbols	1-1
1.2. Abbreviations and Acronyms	1-2
2. Intended use and safety information	2-1
2.1. General description of the LipoCollector® 3	2-1
2.2. Intended use	2-1
2.3. Meaning of the safety symbols	2-1
2.4. Significance of the user manual, instruction of medical staff	2-2
2.5. General safety instructions	2-2
2.6. Compatibility information	2-3
2.6.1. Interface specification	2-3
2.7. First-time use	2-3
2.8. Disposal	2-3
3. Assembly/ disassembly of the LipoCollector® 3	3-1
3.1. Components of the LipoCollector® 3	3-1
3.2. Assembly of the LipoCollector® 3	3-2
3.3. Attachment of the suction tube and the connection tubing	3-5
3.4. Disassembly of the LipoCollector® 3	3-6
3.5. Advices relating to the disassembly of the LipoCollector® 3	3-7
3.5.1. Removal of the sealing rings	3-7
3.5.2. Removal of the collection container from the foot ring	3-8
3.5.3. Removal of the mesh filter	3-8
4. Fat harvesting with the LipoCollector® 3	4-1
4.1. Functional principle of the LipoCollector® 3	4-1
4.2. Pre-filtration through the basket	4-2
4.3. Gradual pressure reduction	4-2

4.4.	Improvement of the lipoaspirate quality	4-3
4.4.1.	Fat volume and liquid content in the collected lipoaspirate	4-3
4.4.2.	Removal of the excessive liquid from the LipoCollector® 3	4-4
4.4.3.	Fat extraction from the collection container	4-5
5.	Processing of the LipoCollector® 3	5-1
5.1.	General information	5-1
5.1.1.	Standards	5-1
5.1.2.	Compatibility	5-1
5.1.3.	Selection of the processing method	5-1
5.1.4.	Automated cleaning and disinfection	5-2
5.1.5.	Control and checking	5-2
5.1.6.	Cleaning, disinfection and sterilisation methods	5-2
5.1.7.	Preparation of reprocessing at the place of use	5-3
5.2.	Manual pre-cleaning	5-4
5.3.	Automated cleaning and thermal disinfection	5-5
5.3.1.	Cleaning agents	5-5
5.3.2.	Automated cleaning and disinfection	5-6
5.3.3.	Sterilisation after automated cleaning	5-7
5.3.4.	Information on validation of reprocessing	5-7
6.	Fault diagnosis and troubleshooting	6-1
6.1.	Lack of suction power owing to insufficient vacuum	6-1
6.1.1.	Blockage in the system	6-1
6.1.2.	Leakage in the system	6-3
6.2.	Localisation and elimination of faults of system components	6-4
6.3.	Watery lipoaspirate	6-5
7.	Technical data	7-1
8.	Accessories, spare parts and extras	8-1
8.1.	Accessories	8-1

8.2. Spare parts	8-1
8.3. Extras	8-1
9. Liability, warranty and customer service	9-1
9.1. Liability and warranty	9-1
9.2. Customer service	9-1

1. Introduction









Thank you for choosing a Human Med product.





The LipoCollector® 3 is a high-quality and effective medical device for collecting, filtering and concentrating the lipoaspirate that subsequently may be used for an autologous fat transfer or laboratory purposes without further treatment.

This user manual contains important information about the intended use of the LipoCollector® 3 and the correct reprocessing of its components. It shall be used for training of medical staff as well as reference guide and, therefore, should always be readily available to the medical personnel.

To be able to use the LipoCollector® 3 in a reliable, safe and effective manner, please read these instructions prior to its use and observe all safety information.

1.1. Symbols

Symbol	Explanation
	This symbol refers to the manufacturer of the medical device.
	This symbol signifies that the device is in conformity to the specifications of the Council Directive 93/42/EEC relating to medical devices; and the manufacturer works with a quality assurance system audited by the Notified Body no. 0482.
REF	Item number and description
	This symbol signifies that the following number is the batch code of the product.
	This symbol indicates the maximum date until which the product may be used.
	This symbol signifies that the user manual and other relevant instructions must be read and followed.
	This symbol signifies that the medical device has been sterilized with ethylene oxide.
	This symbol signifies that the medical device has not been sterilized.
	This symbol signifies that the medical device must not be resterilized.

	This symbol signifies that the medical device is not intended for reuse.
	This symbol signifies that the medical device shall not be used if its packaging is damaged.
	This symbol signifies that the medical device shall be stored under cover protected from humidity.
	This symbol signifies that the medical device shall be stored protected from heat (sunlight).

1.2. Abbreviations and acronyms

Abbreviation/ Acronym	Explanation
GTC	General Terms & Conditions
BEAULI	Berlin Autologous Lipotransfer: Method for breast augmentation and reconstruction using autologous fat
CDC	Centers for Disease Control and Prevention
DGHM	Deutsche Gesellschaft für Hygiene und Mikrobiologie (German Society for Hygiene and Microbiology)
DIN EN	German Version of an European Standard, issued by the German Institute for Standardization
FDA	Food and Drug Administration
ISO	International Organization for Standardization
pH-value	Measure of the acidic or basic character of an aqueous solution
PSU	Polysulfone (high temperature-resistant plastic)
RKI	Robert Koch Institute
DM water	Demineralized (fully deionized and fully desalinated) water
WAL	Water-jet Assisted Lipoplasty

2. Intended use and safety information

2.1. General description of the LipoCollector® 3

The LipoCollector® 3 is used to collect the lipoaspirate harvested in liposuctions, preferably water-jet assisted liposuctions (WAL), and to separate the ideally intact fat cells from the residual liquid for laboratory purposes or autologous fat transfer. The amount that can be collected in the LipoCollector® 3 under sterile conditions in a gentle and time-saving way is up to 1000 ml.

The LipoCollector® 3 serves to filter lipocytes and connective tissue from the lipoaspirate collected during water-jet assisted lipoplasty. The lipoaspirate is firstly collected in the container. Owing to its physical buoyancy the fat cell material is “floating” on the liquid surface while the irrigation fluid is led into the waste container. A special basket holds strands of connective tissue in the sterile collection container even if the suction power gets stronger.

The LipoCollector® 3 additionally offers the possibility to filter the excess fluid out of the lipoaspirate and to remove it by means of a drain. In this way, the liquid in the lipoaspirate is reduced significantly.

Particular extraction cannulas are used to extract the harvested fat cells from the LipoCollector® 3; they are included in the scope of delivery of the LipoCollector® 3.

The BEAULI® infiltration cannulas manufactured by Human Med may be used for direct reinjection of the autologous fat tissue during a plastic-aesthetic or reconstructive surgery.

Compared to conventional procedures, the use of the LipoCollector® 3 substantially simplifies the process of harvesting autologous fat tissue.

2.2. Intended use

The LipoCollector® 3 is intended for collecting, filtering and harvesting autologous fat tissue during a Water-jet Assisted Lipoplasty (WAL). The device may be used in outpatient as well as inpatient surgeries. The prerequisite for optimal use of the device are functioning suction equipment suitable for WAL and appropriate sterile instruments suitable for autologous fat harvesting.

Human Med does not guarantee the quality of the autologous material collected by means of the LipoCollector® 3 and assumes no liability for any performed surgical procedure using the extracted tissue or for their results.

2.3. Meaning of the safety symbols



This symbol characterizes a hazard that may cause personal injury.



This symbol characterizes a hazard that may cause material damage.



This symbol characterizes a hazard that may cause a failure or malfunction of the medical device.

Please pay particular attention to the safety information in each chapter.

2.4. Significance of the user manual, instruction of medical staff

The user manual represents an important part of the product safety concept. Therefore, every medical professional who is concerned with

- preparation, setup, operation, disassembly, cleaning and disinfection, packaging and storage

of the device and the instruments, must read the user manual and the instructions for use of the instruments.



Only medical professionals who have been trained in this method are allowed to use the LipoCollector® 3 in strict adherence to the present instructions for use.

2.5. General safety instructions



The LipoCollector® 3 and its accessories are only to be used under ambient conditions that guarantee the strict adherence to the surgical hygiene management.



Dropping the lid or other heavy parts of the LipoCollector® 3 may cause injuries! Always handle with the greatest care and minimize the height of drop.



Prior to first intended use a test run is necessarily to be made in a 'usual' liposuction in which the aspirate can be discarded, since the surgeon's technique may also affect the fat harvesting and, therefore, may have to be adjusted to optimize the results.



Dropping or other strong application of force may damage the components of the LipoCollector® 3; this may impair the functioning of the device. Always handle with care.



Only original parts and accessories must be used. For details, see chapter 8.

2.6. Compatibility Information

If the LipoCollector® 3 is not used in combination with the body-jet® or any other suction lipoplasty system manufactured by Human Med, a FDA cleared suction lipoplasty system including appropriate liposuction cannulae and connection tubing (FDA Product Code MUU, Regulation Number 21 CFR 878.5040) should be applied. The use of FDA cleared syringes (e.g. 50 cc syringes, Luer-Lock) and Luer-to-Luer connectors is also recommended.

2.6.1. Interface specification

The tubing must be able to withstand the amount of negative pressure generated by the suction pump without collapsing (required tubing see Chapter 3.3. Attachment of the suction tube and the connection tubing.)

2.7. First-time use

The LipoCollector® 3 is supplied as a set made up of several individual components.

After checking that the packaging is undamaged and the content is complete, the disposable components labeled as sterile, are separated from the rest and stored.

All components delivered unsterile must be cleaned, disinfected and sterilized before their first-time use according to the processing instructions included in this user manual.

2.8. Disposal

The LipoCollector® 3 has to be disposed of at the end of its service life according to the applicable national regulations relating to the disposal of medical waste.

Dispose of the single-use components immediately after use!



The single-use components may contain germs harmful to health.

The single-use components must be disposed of in strict adherence to the legal hygiene regulations. Used medical devices must be disposed of in closed containers for infectious waste. Details are to be taken from the hygiene plan of the respective hospital.

3. Assembly/ disassembly of the LipoCollector® 3

3.1. Components of the LipoCollector® 3

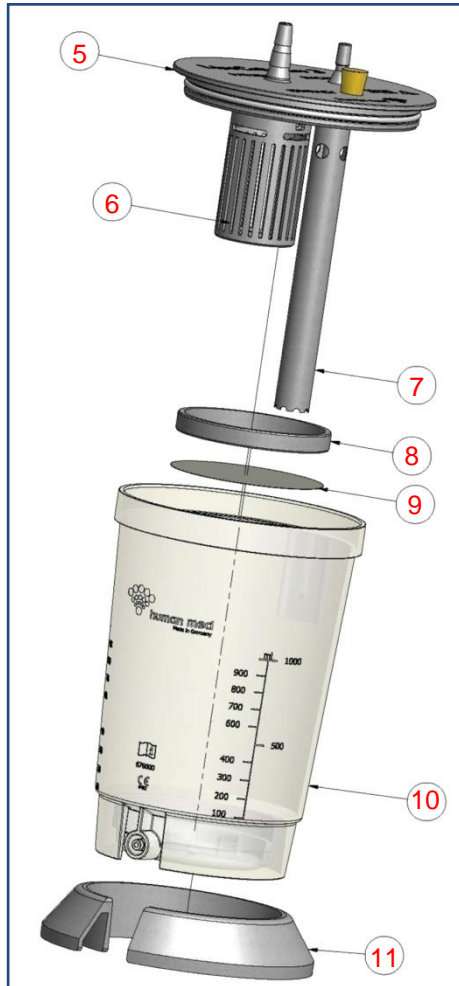

Fig. 3.2: Components of the LipoCollector® 3

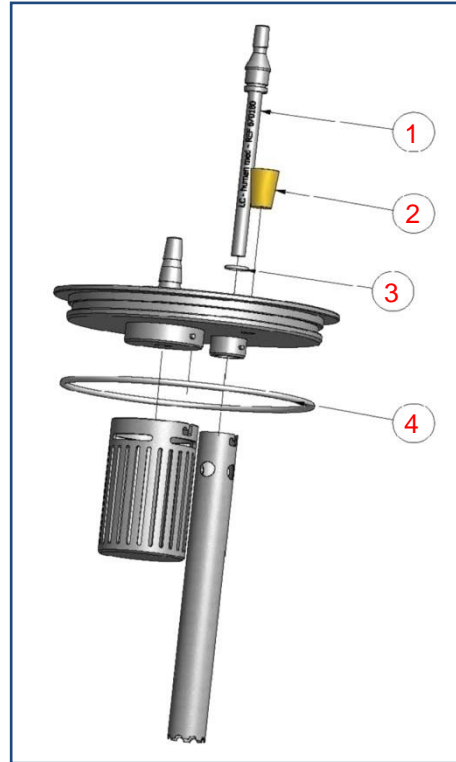

Fig. 3.1: Components of the LipoCollector® 3

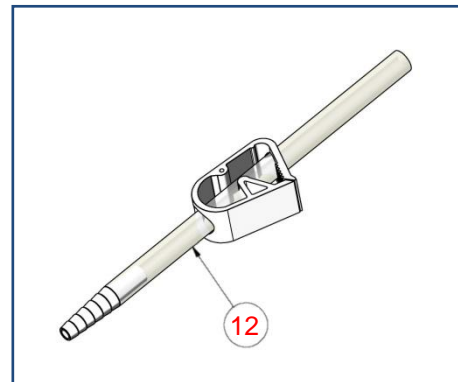

Fig. 3.3: Components of the LipoCollector® 3

Legend

1	Suction pipe	7	Separation pipe
2	Sealing plug	8	Fixation ring
3	Sealing ring for suction pipe	9	Mesh filter
4	Sealing ring for lid	10	Collection container
5	Lid with connection port "PATIENT"	11	Foot ring
6	Basket	12	Drain

3.2. Assembly of the LipoCollector® 3



Visually check all parts of the LipoCollector® 3 for damage, wear and possible fouling. Do **not** assembly if any individual part shows damages, wear and/ or fouling.



The complete LipoCollector® 3 is to be assembled under aseptic conditions using the supplied sterile single-use parts (extraction cannula, sealing rings for lid and connection port of the suction pipe, sealing plug, mesh filter and drain).



After sterilization all parts of the LipoCollector® 3 must sufficiently cool down (below body temperature) before they can be used.



Step 1:

First, insert the mesh filter (9) into the collection container (10). Then, put the fixation ring (8) on it.

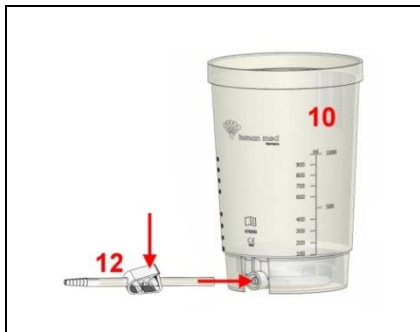

Step 2:

Attach the drain (12) to the drainage opening of the collection container (10) and close the tube clamp of the drain.

ATTENTION:

The tube clamp must be closed so that the vacuum can be built up.

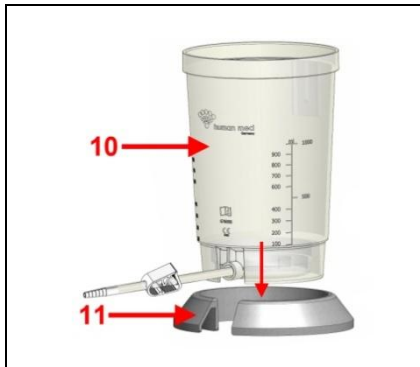

Step 3:

Put the collection container (10) into the foot ring (11).

ATTENTION:

When putting the collection container (10) into the foot ring (11), the drain attached to the drainage opening of the collection container must be in the gap of the foot ring.

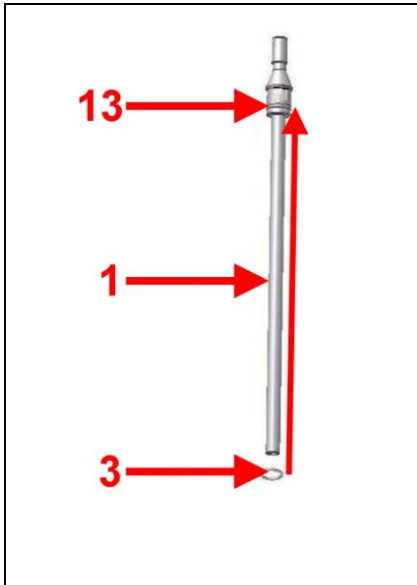

Step 4:

Select a suction pipe (1) according to the desired amount to be collected, and put the compatible sealing ring (3) from below into the groove of the connection port (13) on the upper end of the selected suction pipe (1).

ATTENTION:

Take care that the sealing ring perfectly fits into the groove.

Do not stretch the sealing ring (3) too much; this could impair its elasticity and lead to leakage of the LipoCollector® and reduction of the suction power.

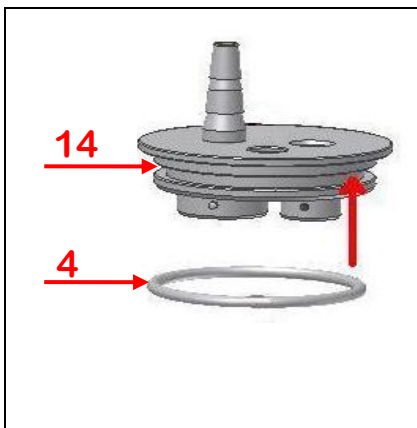

Step 5:

Put a new sealing ring (4) from below into the groove of the lid (14).

ATTENTION:

Take care that the sealing ring perfectly fits into the groove.

Do not stretch the sealing ring (4) too much; this could impair its elasticity and lead to leakage of the LipoCollector® and reduction of the suction power.



In case of damaged sealing rings silicone particles may fall into the collected lipoaspirate. For this reason, avoid any damage.

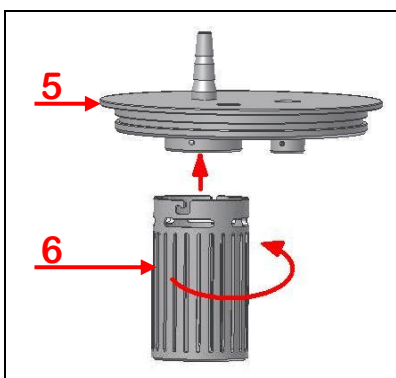

Step 6:

Attach the basket (6) to the bayonet nut connector (large diameter) provided for this on the inside of the lid (5). Fasten the basket (6) by turning it slightly until it latches.

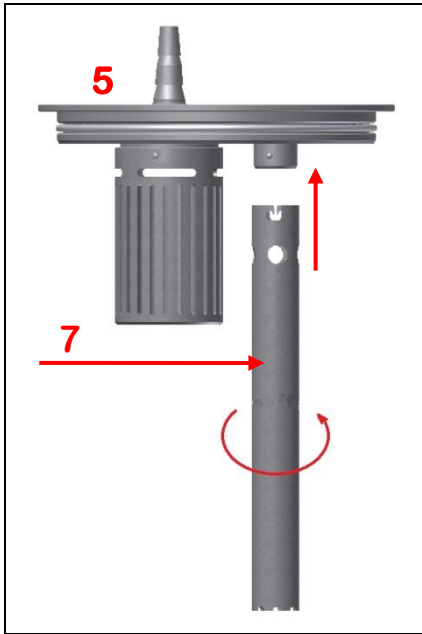

Step 7:

Attach the separation pipe (7) to the bayonet nut connector (small diameter) provided for this on the inside of the lid (5). Fasten the separation pipe (F) by turning it slightly until it latches.

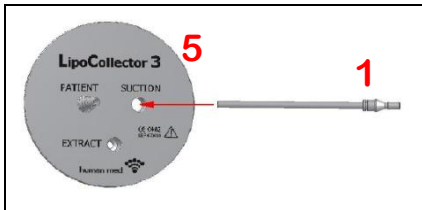

Step 8:

Push the suction pipe (1) through the orifice SUCTION provided for this in the lid (5) of the LipoCollector® 3.

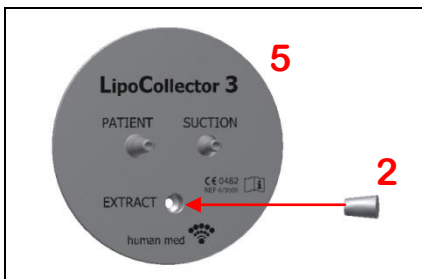

Step 9:

Put the sealing plug (2) into the orifice EXTRACT provided in the lid (5) of the LipoCollector® 3.



Do not put the completed lid down; otherwise the basket and the separation pipe could get untightened from the bayonet nut connector. Always hold the completed lid vertically.

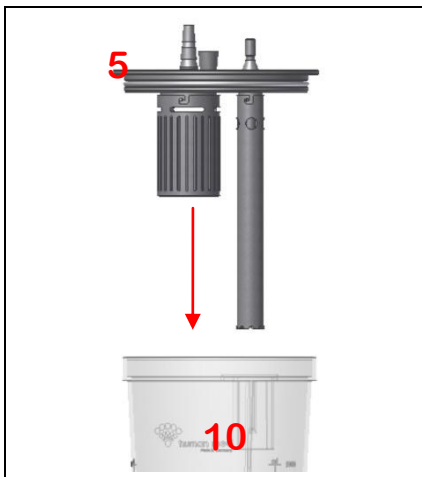

Step 10:

Then insert the lid (5) assembled as described in step 3 to 9 vertically into the collection container (10) of the LipoCollector® 3.



Do not put the completed lid down; otherwise the basket and the separation pipe could get untightened from the bayonet nut connector. Always hold the completed lid vertically.

The LipoCollector® 3 is now ready to be connected with the suction tube and the connection tubing.

3.3. Attachment of the suction tube and the connection tubing

All tubing used must be able to withstand the negative pressure created by the suction device without collapsing. Each connecting component between the LipoCollector® 3 and the patient must be suitably biocompatible for the subsequent use of the lipoaspirate.

Various types of tubing are used within the system:

- 1) The suction instrument (irrigation/ aspiration cannula) is connected with the LipoCollector® 3 (port “PATIENT”) by means of the **suction tube**. This suction tube should be a 7 x 11 mm sized hose with a socket CH 32.
- 2) The aspirated irrigation fluid is conveyed through the **connection tubing** from the LipoCollector® 3 (port “SUCTION”) into the suction container/ bag attached to the suction device. The connection tubing should be a 7 x 10 mm sized hose with a socket CH 30.

Attach one end of the connection tubing to the connection port (H) of the suction pipe on the top side of the lid (“SUCTION”). The other tubing end (socket) is to be attached to the suction container of the used suction device.



When attaching the connection tubing, ensure that the tubing is not pushed too far onto the connection port “SUCTION”; otherwise it will be difficult to pull it off during disassembly.



Do not attach the connection tubing directly to the used suction device but always to the suction container/ bag.

Likewise, observe the user manual for the used suction device!

Attach the suction tube of the suction instrument (irrigation/ aspiration cannula) to the port “PATIENT“ on the top side of the lid of the LipoCollector® 3.



When attaching the connection tubing and the suction tube, take care that both are strain-relieved.

To ensure a stable position of the LipoCollector® 3, fasten all tubing to the instrument table near the LipoCollector® 3 using towel forceps with tube clip, or holding and drape clamps.

3.4. Disassembly of the LipoCollector® 3

Before disassembling the LipoCollector® 3, aspirate residues should be removed from the collection container. They must be disposed of in strict adherence to legal hygiene regulations. Details can be taken from the hygiene plan of the hospital concerned.



The lipoaspirate residues may contain germs harmful to health.

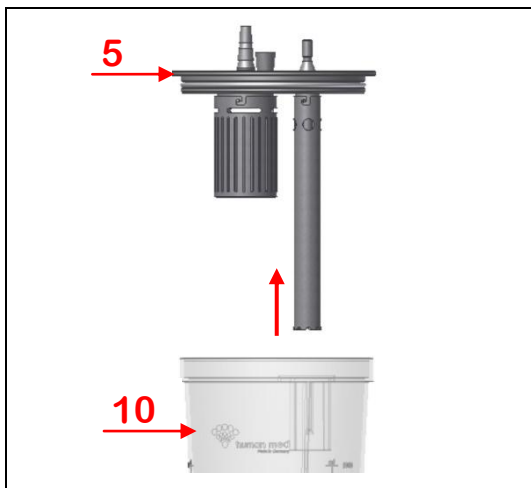

Step 1:

Pull the connection tubing from the port “SUCTION” and the suction tube from the port “PATIENT”.

The connection tubing and the suction tube are single-use products and must be disposed of.

Step 2:

Remove the lid (5) from the collection container (10).

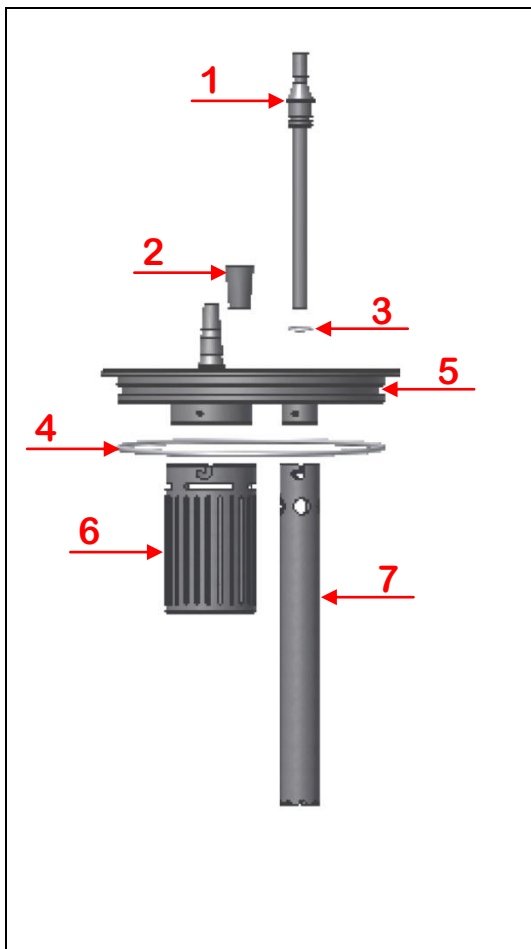

Step 3:

Remove the suction pipe (1) from the lid (5). The suction pipe must undergo subsequent reprocessing.

Step 4:

Pull the sealing plug (2) from the lid (5). The sealing plug is a single-use product and must be disposed of.

Step 5:

Carefully remove the basket (6) and the separation pipe (7) from the lid (5). The basket and the separation pipe must undergo subsequent reprocessing.

Step 6:

Remove the sealing rings (3 and 4) from the lid and from the connection port of the suction pipe (1) (see tip in section 3.5.1 on page 3-7).

The sealing rings are single-use products and must be disposed of.



Step 7:

Pull the drain (12) off the drainage opening (15) of the collection container (10).

The drain is a single-use product and must be disposed of.

Step 8:

Remove the fixation ring (8) and the mesh filter (9) from the collection container (10) (see advice in section 3.5.3 on page 3-8).

The mesh filter is a single-use product and must be disposed of. The fixation ring must undergo subsequent reprocessing.

Step 9:

Take the collection container (10) out of the foot ring (11) (see advice in section 3.5.2 on page 3-8).

The collection container and the foot ring must undergo subsequent reprocessing.

3.5. Advices relating to the disassembly of the LipoCollector® 3

3.5.1. Removal of the sealing rings

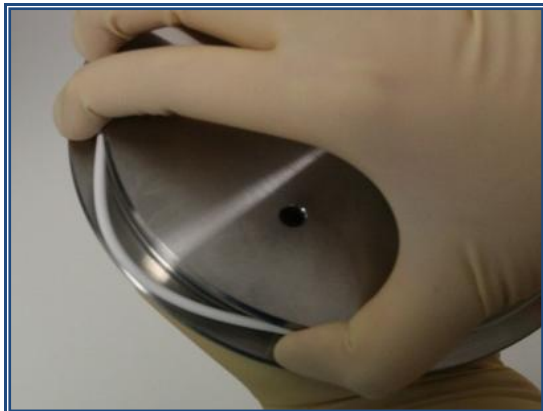

Fig. 3.4: Remove the sealing ring

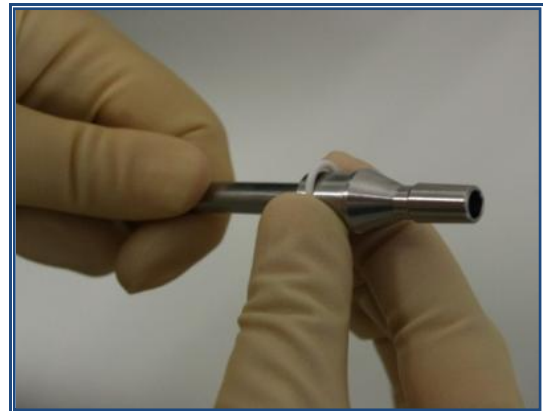

Fig. 3.5: Remove the sealing ring

Slightly push the sealing rings out of the grooves and remove them (see Fig. 3.4 and Fig. 3.5).



The sealing rings and the sealing plug are single-use products and must not be reprocessed and sterilized.

Their reuse may lead to loss of material elasticity and to contamination of the aspirate by silicone particles. That may cause foreign-body reactions of the patient and, therefore, **reuse is explicitly prohibited.**

3.5.2. Removal of the collection container from the foot ring



Fig. 3.6: Remove the collection container from the foot ring

Push the collection container from below out of the foot ring (see Fig. 3.6).

ATTENTION:

Ensure that you securely hold the collection container!

3.5.3. Removal of the mesh filter



Fig. 3.7: Remove the mesh filter



Fig. 3.8: Remove the mesh filter

If you press your finger onto the middle of the mesh filter, the mesh filter edge bends upwards (see Fig. 3.7); you can simply remove the mesh filter (see Fig. 3.8). Be cautious with the edge of the mesh filter.

Likewise, you can just turn the collection container over and let the mesh filter drop out.

4. Fat harvesting with the LipoCollector® 3



Fat cells are sensitive to temperatures! The ambient temperature for the collected fat tissue must be at least 20°C (but not higher than 37°C).

Note: If pre-warmed (not warmer than body temperature) infiltration/irrigation fluid has not been used yet, it should definitely be considered to be used for surgical interventions including fat cell harvesting.



In order to minimize damages to the adipose tissue being collected, the suction vacuum must not exceed -500 mbar.

Note: The composition of the anesthetic infiltration fluid, air contact and the time of storage of the harvested fat outside of the human body may affect the vitality of the harvested fat cells.

4.1. Functional principle of the LipoCollector® 3

The LipoCollector® 3 is a filtering device for the gentle separation of fat cells from a mix of liquid and connective/ adipose tissue harvested during a liposuction, preferably a Water-jet Assisted Lipoplasty (WAL).

The functional principle of the LipoCollector® 3 consists in separating the fat from the liquid solely by the physical phenomena of buoyancy and gravity. The less dense fat is “floating” on top of the liquid while the liquid is continuously aspirated through the separation pipe, once the filling level has reached the suction pipe inside of the separation pipe (principle of communicating pipes). The use of the mesh filter and the drain helps to reduce the liquid content of the lipoaspirate to less than 20%. The suction flow is routed away from the lipoaspirate so that the mechanical strain on the collected fat tissue is minimized.

Once the LipoCollector® 3 has been properly assembled and connected to the suction device (see section 3.2), it is ready for collection and filtration of the lipoaspirate harvested during a liposuction.

After the suction device has been switched on, the incoming lipoaspirate first passes through the basket of the LipoCollector® 3 where larger tissue strands of the lipoaspirate are caught in the basket grid.

During the next phase, the lipoaspirate runs into the collection container. Due to buoyancy and gravity, the fat begins to sediment and “floats” on the liquid surface.

Seeping through the mesh filter, the liquid collects at the bottom of the container. Likewise, the mesh filter helps to prevent that fat tissue is unintentionally aspirated into the suction bag/ container (waste).

The mesh filter should always be surrounded by liquid so that it cannot get clogged. It is, therefore, advisable to fill approx. 100 ml physiological saline in the collection container before starting liposuction.

The excessive liquid collecting at the bottom of the container is led by suction into the separation pipe and, from there, into the suction bag/ container. This process starts automatically when the maximum filling level has been reached.

Likewise, you may use the LipoCollector® 3 without mesh filter and fixation ring. In either case, it is important that the drain is attached to the drainage opening and its tube clamp is closed. Please note that, when using the LipoCollector® 3 without mesh filter and fixation ring, the scale value on the collection container does not indicate the actual volume of lipoaspirate.

4.2. Pre-filtration through the basket

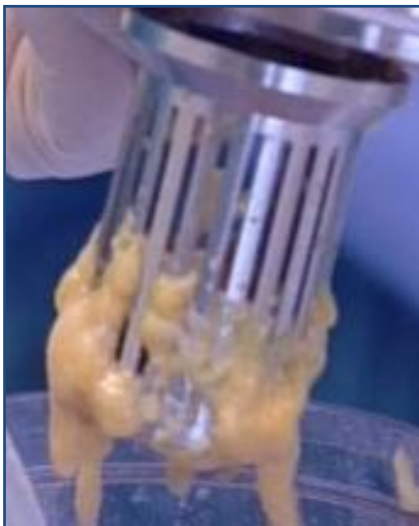

Fig. 4.1: Basket as pre-filter

The LipoCollector® 3 is equipped with a basket (Fig. 4.1) serving as a pre-filter.

The incoming aspirate first runs through this basket where larger tissue strands of the lipoaspirate are caught in the basket grid. This helps to minimize the risk that the mesh filter is clogged and the cannulas used for fat extraction from the collection container and for subsequent reinjection are blocked. Likewise, the harvested fat tissue is, as much as possible, preserved due to the prevention of pressure peaks.

4.3. Gradual pressure reduction

Owing to the floating filtration, the fat may get wasted from the LipoCollector® 3 into the suction bag/ container, particularly in case of a strongly stirred lipoaspirate (e.g. caused by fluctuations in pressure, waving of the suction tubing). Therefore, proceed in **a calm and smooth manner** during liposuction.

While working with the LipoCollector® 3 the pressure in the system should not be dropped abruptly. In case the suction system should be opened from the patient side, a large pressure gradient would be generated due to the ambient air pressure causing the suction tubing to wave and the lipoaspirate to eject intensely which may impair the filtration.



Release the bypass hole of the cannula slowly (by rolling the thumb)!



Do not pull the cannula abruptly from the incision when vacuum pressure has been built up!

4.4. Improvement of the lipoaspirate quality

The **vacuum** should only be as high as required for the desired liposuction result. A maximum vacuum pressure of -500 mbar is recommended. Thus, the mechanical strain on the fat tissue is reduced, which is likewise favorable for the quality of the fat cell concentrate.

Operating with smooth cannula movements helps to ensure trouble-free collection and optimal extraction of the fat from the lipoaspirate. In this way, you avoid excessively large connective tissue pieces in the lipoaspirate.

4.4.1. Fat volume and liquid content in the collected lipoaspirate



Fig. 4.2: Suction pipe

The volume indicated on the selected suction pipe specifies the maximum amount of fat that may be harvested with this suction pipe.

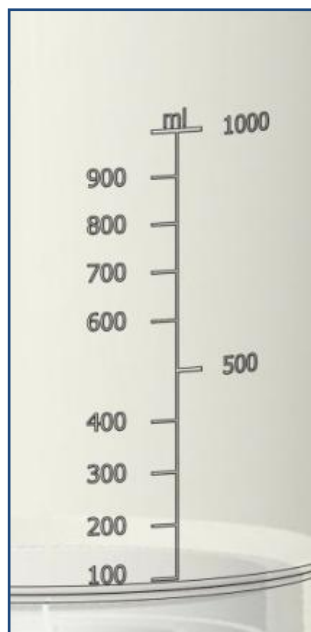

Fig. 4.3: Scale of the collection container

The actual amount of usable fat in the lipoaspirate varies due to several factors (as e.g. used fluid volume, suction velocity and duration, oil content etc.).

During the floating filtration process in the LipoCollector® 3, the volume of collected fat continuously increases top-down in relation to the liquid volume („the fat is growing downwards“) until the bottom is reached and the fat flows into the separation pipe. The collection process ends at the latest when the fat runs over into the suction pipe.

The approximate amount of the lipoaspirate can be read off from the scale of the collection container.



Pay attention to the fat level in the container in order not to unintentionally aspirate fat into the suction bag/ container (waste).

After finishing the collection, the fat should still be left for a short period in the LipoCollector® 3. During this time the sedimentation of the collected aspirate can continue, i.e. more and more liquid can be separated. Moreover, the short period of rest helps to prevent the clogging of the mesh filter.

4.4.2. Removal of the excessive liquid from the LipoCollector® 3

Prior to fat extraction, the excessive liquid, if existing, should be removed from the bottom of the LipoCollector® 3 by drainage or suction.

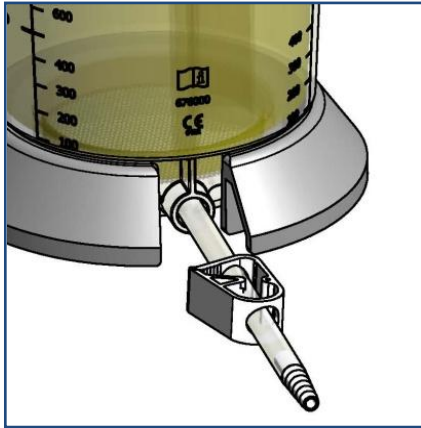

Fig. 4.4: Drain with tube clamp

The excessive liquid is removed from the LipoCollector® 3 by means of the drain. Proceed as follows:

- (1) Switch the suctioning off.
- (2) Open the tube clamp of the drain and let the excessive liquid drain off into a collecting vessel.

Alternatively, you may use the suctioning function of the suction device:

- (3) For this, remove the connection tubing from the connection port “SUCTION“, attach it to the drain and open the tube clamp.
- (4) Set the minimal vacuum at the suction device. If the liquid is suctioned off very slowly or is not suctioned off at all, the vacuum can be gradually increased up to a maximum of -500 mbar. The vacuum level and the suction time affect the fat viscosity, i.e. the liquid contained in the fat.



If the vacuum level is too high, the fat harvested might accidentally get into the suction bag/ container.

- (5) Open the tube clamp of the drain to apply vacuum below the mesh filter. The liquid seeping through and collecting below the mesh filter is suctioned off now. Due to the suction below the mesh filter, even more liquid is extracted from the lipoaspirate above the mesh filter.
- (6) Close the tube clamp of the drain when finishing the suctioning.
- (7) After completion of the suctioning switch the suction unit off.



If the excessive liquid does not drain off or is not suctioned off, then, in all probability, the mesh filter is clogged. For information on how to rectify this fault, see section 6.3.

The harvested fat can be immediately extracted now.

4.4.3. Fat extraction from the collection container



Fig. 4.5: Extraction cannula

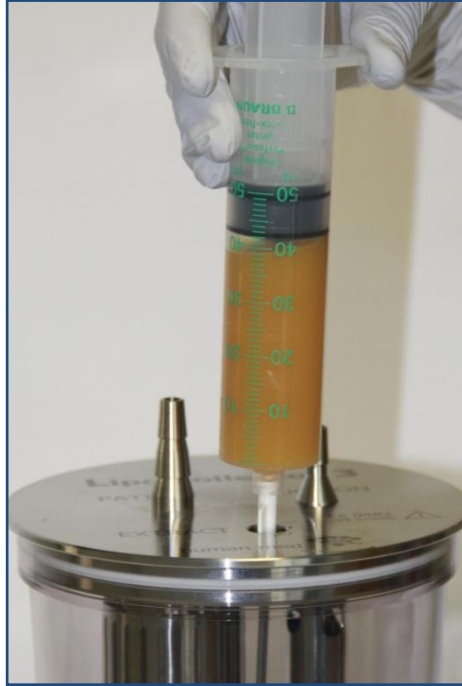

Fig. 4.6: Extraction of the fat cells

The harvested fat is extracted through the orifice „EXTRACT” provided in the lid of the LipoCollector® 3 using sterile single-use syringes and a sterile extraction cannula (REF no. 665010). The sealing plug is to be removed from this orifice before.

The extraction cannula is intended to be used for transferring the harvested fat from the LipoCollector® 3 into devices that are suitable for the subsequent reinjection of the autologous fat (e.g. 50 ml single-use syringes).

The Luer-to-Luer connector (female/female), Ref no. 5206634, is available for transfer from syringe to syringe.

The BEAULI infiltration cannulas manufactured by Human Med (REF No. 655020, 655030 and 655031) or other sterile and biologically safe tissue injection cannulas can be used for reinjection of the fat transferred into single-use syringes.

5. Processing of the LipoCollector® 3

5.1. General information

The LipoCollector® 3 is intended to be reprocessed after use. To prevent the patient from infections, all components suited for processing must be reprocessed each time before use. The design and the material of the equipment only allow applying specific reprocessing methods. They are described in this chapter.

5.1.1. Standards

The appropriate processing procedure is to be selected and carried out in accordance with the applicable national hygiene-related regulations and local guidelines of hospital hygiene. Human Med recommends strictly respecting the guideline „Hygiene Requirements for Reprocessing Medical Devices“ published by the Commission for hospital hygiene and infection prevention (KRINKO) at the Robert-Koch-Institute (RKI) and the Federal Institute for Drugs and Medical Devices (BfArM) (see Bundesgesundheitsblatt 2012, Issue 55, page 1244-1310).

Local standards and provisions are to be provided by the local responsible for hospital hygiene.

5.1.2. Compatibility

Micro-biological compatibility

Micro-biological compatibility signifies that the LipoCollector® 3 has been successfully reprocessed and sterilized using the methods described in these instructions.

Material compatibility

Material compatibility signifies that after using the agents prescribed no adverse effects on the material of the LipoCollector® 3 parts have been found to date (see also **Material durability**). Material compatibility does not signify that a specific degree of micro-biological compatibility and biological safety according to the ISO 10993 requirements can be guaranteed.

5.1.3. Selection of the processing method

According to the above mentioned RKI guideline the LipoCollector® 3 is classified as critical medical device with increased requirements on reprocessing (B critical).

After thorough cleaning, this medical device must be **steam-sterilized** prior to each use on the patient.



Basically, automated cleaning and thermal disinfection are required.

Factory-new, unsterile components of the LipoCollector® 3 are to be treated like used products. They must necessarily be cleaned before disinfection and sterilization.

5.1.4. Automated cleaning and disinfection

When selecting the washer-disinfector, pay attention to the following specifications:

- The washer-disinfector is effectually certified and accredited (e. g. by DGHM or FDA or CE marked acc. to DIN EN ISO 15883);
- it uses an approved program for thermal disinfection (at a temperature and a holding time corresponding to A0 = 3000);
- the used program includes a sufficient number of rinse cycles to remove cleaning agent residues;
- only sterile or low-germ (max. ten (10) germs/ml) and low-endotoxin (max. 0,25 endotoxin units/ml) water is used for rinsing;
- the drying air is filtered and prepared for this purpose;
- the washer-disinfector is maintained and inspected regularly.

When selecting the cleaning agent, please make sure that

- it is basically suited for cleaning medical devices;
- the used chemicals are compatible with the device components (see also **Material durability**).

Strictly adhere to the concentrations indicated by the producer of the cleaning agent.

5.1.5. Control and checking

All disinfection and sterilization procedures must be reviewed regularly. To control the sterilization, all sterilization procedures are to be regularly checked using an appropriate biological indicator.



Cleaning, disinfection and sterilization must only be carried out according to the state of the art by trained staff in rooms specifically provided for this purpose.

5.1.6. Cleaning, disinfection and sterilization methods

The cleaning, disinfection and sterilization methods described in this chapter have been thoroughly tested for use with the LipoCollector® 3.

Automated cleaning and disinfection

An independent, accredited testing laboratory has proven the basic suitability of the LipoCollector® 3 components for effective automated cleaning and disinfection using a washer-disinfector of type Belimed WD100, programme 8 and the following cleaning agents for testing:

- deconex® 24 LIQ, 0,5% (V/V) – highly alkaline cleaner
- deconex® 26 plus, 0,25% (V/V) – neutralizer

(both produced by Borer Chemie AG).

Steam sterilization in fractionated vacuum process

The sterilization is to be done at a sterilization temperature of at least 134 °C and at a sterilization temperature holding time of 3.5 minutes in a steam sterilizer that is validated according to the applicable national and international standards.

Material durability

Note: To clean the collection container, only use cleaning agents recommended for cleaning of PSU plastics. In case of doubts, please contact the producer of the cleaning agent and disinfectant.



Do not use phenol-based cleaners and/ or disinfectants, since they might damage the plastic parts of the LipoCollector® 3.



Do not use rinse agents during automated cleaning and thermal disinfection!

These agents are often dosed automatically in many programs of the washers-disinfectors. The use of rinse agents cause stress cracks in the collection container which may shorten its service life.

5.1.7. Preparation of reprocessing at the place of use

Immediately after use still in the operating room, the reusable components of the LipoCollector® 3 are to be prepared for subsequent reprocessing as described in this chapter.

When reprocessing medical devices, **work carefully according to the local safety regulations.**

Preparation and transport

- Remove rough surface soiling with a disposable cloth/ paper towel on site.
- Transport reusable components from the place of use to the reprocessing facilities.

The components can be transported either dry or immersed in fluid. Contaminated components are to be transported in containers in order to prevent the environment and personnel from potential contamination. When transporting dry, make sure that no soiling can dry on the instruments.

- Do not use fixating agents or hot water (> 40°C) since they promote the protein coagulation which impairs the cleaning result.

- Close the container.



The pre-cleaning must be done immediately after use of the LipoCollector® 3.

If used components are left without pre-cleaning over a longer period, dried residues may form incrustations that may be difficult to remove and provoke allergic reactions.

Limitation of reprocessing

Provided that the medical device is used as intended by the manufacturer, the end of its service life is determined by normal wear and tear.

All components of the LipoCollector® 3 have been successfully tested for **thirty-time (30) reprocessing** using the described automated reprocessing procedure including steam sterilization. Further reprocessing cycles beyond this number or other reprocessing and/ or sterilization methods are in the user’s responsibility.

5.2. Manual pre-cleaning

Cleaning agents	A cleaner intended for automated cleaning in a washer-disinfector is to be used.
Immersion of the components for manual pre-rinsing	<p>All components intended for reuse, as suction pipe with connection port, lid with port for connection to patient, basket, fixation ring, separation pipe, collection container and foot ring</p> <p>must be immersed in the alkaline cleaning solution mixed with lukewarm water (DM water if possible) for at least ten (10) minutes or longer in case of stubborn or dried soiling. The concentration is to be selected according to the manufacturer’s specification.</p>
Manual pre-cleaning	<p>Rinse the collection container with approx. 30 °C warm water for about two (2) minutes. Clean the drainage opening of the collection container with a cleaning brush (Ø 4-5 mm) so that there are no visible tissue residues left. Then rinse the collection container again with approx. 20 °C warm water.</p> <p>All other components must be pre-cleaned in the cleaning solution using brushes. This work must be repeated until the brushes and the surfaces and hollow spaces to be cleaned are free of visible contamination. After cleaning rinse all parts with potable water.</p>

5.3. Automated cleaning and thermal disinfection

5.3.1. Cleaning agents

Human Med recommends using the following agents for cleaning the components of the LipoCollector® 3:

- *thermosept® alka clean forte (Schülke & Mayr)*
- *neodisher® Mediclean forte (Dr. Weigert)*
- *highly alkaline cleaners, e.g. deconex 24 LIQ in combination with deconex 26 plus as neutralizer (Borer Chemie AG)*



Only use agents that are approved by the manufacturer for cleaning PSU plastics.

Do not use phenol-based cleaners, since they might damage the plastic parts of the LipoCollector® 3.



Never use rinse agents for automated reprocessing of the collection containers made of PSU!

Note: If possible, the instruments are transported from the place of use to the reprocessing facilities in dry condition in order to avoid that protein can deposit owing to the cleaning agent used.

The water inflow into the washing machines must start at lower temperatures (approx. 20°C) to prevent thermal coagulation of proteins.

All components intended for automated reprocessing, as

suction pipe with connection port, lid with port for connection to patient, basket, separation pipe, fixation ring, collection container and foot ring

are put into the washer-disinfector.



When cleaning the lumen of the suction pipe and the port for connection to patient on the lid, these have to be attached to the hose connectors of the washer-disinfector (preferably on the drawer cart of the machine).

Likewise, the drainage opening of the collection container has to be connected by means of a hose (ID 6,2 - 6,4 mm) to a hose connector of the washer-disinfector.

Note: Use silicone hoses for connection of the above mentioned components to the connectors of the washer-disinfector.

5.3.2. Automated cleaning and disinfection

The following steps have to be made when using a washer-disinfector. The process described below reflects the reprocessing procedure as validated by Human Med.

Automated pre-cleaning	Pre-rinse twice with 20°C warm water for five (5) minutes each pre-rinse cycle.
Automated cleaning	Cleaning with 55°C hot water mixed with cleaner as specified by the cleaning agent manufacturer and at a temperature holding time of at least fifteen (15) minutes
First rinse cycle	With 20°C warm DM water mixed with a neutralizer as specified by the cleaning agent manufacturer (e.g. deconex 26 plus) for ten (10) minutes
Second rinse cycle	With 20°C warm DM water for five (5) minutes
Thermal disinfection	Carry out thermal disinfection with DM water; Connect the drainage opening of the collection container by means of a hose (ID 6,2 - 6,4 mm) to a hose connector of the washer-disinfector. Human Med has carried out the reprocessing at a temperature of 90 °C and a temperature holding time of five (5) minutes. It is advisable to perform a separate temperature validation as per the recommendations relating to the A0 value (acc. to ISO 15883).
Automated drying	At 60 °C for at least 15 minutes
Cooling	The components shall cool down at 30°C.
Maintenance	The components of the LipoCollector® 3 are not intended for maintenance.
Check and inspection	Visually check the components for damage and wear. Check the ports on the lid for deformation; the collection container for cracks, all stainless steel parts for corrosion. Reject any damaged part.

Note: If damaged parts shall be returned to Human Med or to an authorized supplier, these parts must be cleaned, disinfected and sterilized before; documented evidence hereof must be enclosed in the return consignment.

5.3.3. Sterilization after automated cleaning

Packaging	<p>The dried LipoCollector® 3 components must be packed in sterile packaging suited for steam sterilization in accordance with ISO 11607.</p> <p>The packaging must be large enough so that the sealing is not subject to stress.</p>
Sterilisation	<p>Steam sterilization in a fractionated vacuum process at 121°C for at least 15 minutes, and at 134°C for 3,5 minutes has been validated.</p> <p>The sterilization at 134 °C over a maximum period of 30 minutes has been tested; no adverse effects on the material of the LipoCollector® 3 have been detected.</p> <p>In each sterilization procedure, check the history logs and the indicator strips for the respectively used sterilizer for compliance with the required parameters.</p>
Storage	<p>The sterile plastic bags have to be stored in a closed cupboard, protected from light, dust, humidity and extreme fluctuations in temperature. The shelf life is determined by the specifications of the sterile packaging used.</p>



The LipoCollector® 3 is only to be sterilized after it has been disassembled.
Prior to sterilization, make sure that there are no metal parts in the collection container.

5.3.4. Information on validation of reprocessing

If the recommended agents, equipment and processes are not available, it is the user's responsibility to validate the reprocessing method used.

It is the reprocessor's responsibility to ensure that the reprocessing actually performed with equipment, materials and personnel in the reprocessing facility achieves the desired results. This requires validation and routine monitoring of the process.

Likewise, any deviation from the recommendations provided must be properly evaluated by the reprocessor for effectiveness and potential adverse consequences.

List of alkaline cleaning agents, particularly suited for automated cleaning of the LipoCollector® 3 collection container made of PSU plastic:

Trade name	Manufacturer	Remarks
Thermosept alca clean	SCHÜLKE & MAYR	Tenside-based alkaline cleaner, possible ph value > 10
Neodisher Mediclean forte	DR. WEIGERT	
<i>2-component cleaner system for automated cleaning</i>		
deconex 24 LIQ	Borer Chemie AG	Highly alkaline special cleaner
deconex 26 plus	Borer Chemie AG	Acidic neutralizer

6. Fault diagnosis and troubleshooting

6.1. Lack of suction power owing to insufficient vacuum

Since the LipoCollector® 3 is integrated into the used suction system, all required connections must be pressure-stable, i.e. no leak air must enter the system. However, experience shows that this is a frequent source of operating errors.

Note: It takes about ten (10) seconds to build up the full vacuum pressure in the collection container of the LipoCollector® 3.

Possible indications of a vacuum lack:

- No or only a small amount of aspirate in the LipoCollector® 3 or suction bag/container;
- slow flow in the suction tube;
- low vacuum pressure indicated on the suction device

General causes for errors:

- Blocked irrigation/ aspiration cannula;
- leaks within the system;
- damage to the collection container caused by improper processing or operating errors;
- incorrect or pinched hose connections;
- incorrect vacuum setting

Fault localisation:

The total system (applicator with cannula, LipoCollector® 3, connection tubing, suction container including suction bag and suction device) is properly connected/switched on and set to the maximum vacuum (-500 mbar).

The irrigation/ aspiration cannula is in the adipose tissue (suction holes and by-pass hole are closed).

First check the displayed vacuum value to localise the possible error cause as described in the following sections:

6.1.1. Blockage in the system

Although the device/ the system has been properly installed and the vacuum displayed (-500 mbar) is correct, liposuction/ fat harvesting is not possible.

The probable cause is a blockage in the system. Proceed as follows:

- 1) Open the bypass whole of the suction instrument (irrigation/ aspiration cannula).

- a) If the displayed vacuum falls below -300 mbar, there is probably a blockage in the suction instrument (irrigation/ aspiration cannula).
 - b) If the displayed vacuum value doesn't change, there is probably a blockage between the suction instrument (irrigation/ aspiration cannula) and the suction device.
- 2) Remove the suction tube of the suction instrument (irrigation/ aspiration cannula) from the port "PATIENT" of the LipoCollector® 3:
- a) If the displayed vacuum value falls below -300 mbar, the suction tube is probably blocked.
 - b) If the displayed vacuum value doesn't change, there is probably a blockage between the LipoCollector® 3 and the suction device.
- 3) Remove the connection tubing from the port „SUCTION“ of the LipoCollector® 3.
- a) If the displayed vacuum value falls below -250 mbar, there is probably a blockage in the LipoCollector® 3.
 - b) If the displayed vacuum value doesn't change, there is probably a blockage between the connection tubing and the suction device.
- 4) Remove the hydrophobic filter set from the suction container.
- a) If the displayed vacuum value falls below -250 mbar, the suction container is probably blocked.
 - b) If the displayed vacuum value doesn't change, there is probably a blockage between the hydrophobic filter set and the suction device.
- 5) Remove the hydrophobic filter set from the suction port of the suction device.
- a) If the displayed vacuum value falls below -250 mbar, the hydrophobic filter set is probably blocked.
 - b) If the displayed vacuum value doesn't change, there is probably a blockage in the suction device.

Check the named system components and their connecting points for blockage; replace them if necessary.

Follow the instructions on troubleshooting given in the user manual for the used suction device.

6.1.2. Leakage in the system

In spite of proper installation of the device/ the system the indicated vacuum value is well below -500 mbar; liposuction/ fat harvesting is not possible.

The probable cause is a leakage in the system. Proceed as follows:

- 1) Remove the suction tube of the suction instrument (irrigation/ aspiration cannula) from the port "PATIENT" of the LipoCollector® 3 and seal the port "PATIENT" by hand.

- a) If the displayed vacuum value increases considerably, there is probably a leakage in the suction tube or suction instrument (irrigation/ aspiration cannula).
 - b) If the displayed vacuum value remains too low, there is probably a leakage between the LipoCollector® 3 and the suction device.
- 2) Remove the connection tubing from the port „SUCTION“ of the LipoCollector® 3 and seal the connection tubing by hand (by kinking).
- a) If the displayed vacuum value increases considerably, there is probably a leakage of the LipoCollector® 3.
 - b) If the displayed vacuum value remains too low, there is a leakage between the connection tubing and the suction device.
- 3) Remove the hydrophobic filter set from the suction container.
- a) If the displayed vacuum value increases considerably, there is probably a leakage of the suction bag/ container.
 - b) If the displayed vacuum value remains too low, there is a leakage between the hydrophobic filter set and the suction device.
- 4) Remove the hydrophobic filter set from the suction device.
- a) If the displayed vacuum value increases considerably, there is probably a leakage of the hydrophobic filter set.
 - b) If the displayed vacuum value remains too low, there is a leakage of the suction device.

Check the named system components and their connecting points for blockage; replace them if necessary.

Follow the instructions on troubleshooting given in the user manual for the used suction device.

6.2. Localization and elimination of faults of system components

In order to localize other possible error sources and to eliminate them if necessary, observe the following instructions:

<i>Applicator</i>	<p>Check whether the irrigation/ aspiration cannula is blocked. Suddenly less resistance when moving the cannula in the tissue and a slow flow in the suction tube are symptomatic for a blocked cannula.</p> <p>⇒ Wipe off/ flush the capillary of the applicator</p>
	<p>Check whether the suction tube of the cannula has been correctly connected to the LipoCollector® 3.</p> <p>⇒ Correct the connection</p>
<i>Device, setting, filter, suction container, tubing</i>	<p>Check whether the suction device has been switched on (ON/OFF-button is green, pump noise).</p> <p>⇒ Switch on, see user manual for the used suction device</p>
	<p>Check whether the vacuum has been set correctly.</p> <p>⇒ Correct this setting, see user manual for the used suction device</p>
	<p>Check by closing the suction port of the suction device whether the suction power is set to a sufficient level (max. -500 mbar).</p> <p>⇒ Correct this setting, see user manual for the used suction device</p>
	<p>Check whether the correct suction port (suction bag/ container) has been selected.</p> <p>⇒ Correct this setting, see user manual for the used suction device</p>
	<p>Check whether the overflow protection/ bacteria barrier (if existing) of the used suction device is possibly blocked.</p> <p>⇒ Test and replace the overflow protection/ bacteria barrier as described in the user manual for the used suction device</p>
	<p>Check whether the hydrophobic filter set between suction bag/ container and suction device has been attached correctly.</p> <p>⇒ Correct attachment</p>
	<p>Check whether the single-use suction bag in the suction container has been correctly unfolded or whether it is possibly pinched or damaged.</p> <p>⇒ Correct or correctly insert a new suction bag if necessary</p>

	<p>Check whether the hydrophobic filter in the suction bag is jammed (caused by contact with liquid, e.g. after pouring out the aspirate in case of reuse).</p> <p>⇒ Replace the suction bag</p>
	<p>Check whether the connection tubing between LipoCollector® 3 and suction container/ bag has been correctly attached at both ends.</p> <p>⇒ Correct attachment</p>
<p>LipoCollector® 3</p>	<p>Check whether the lid of the LipoCollector® 3 has been closed correctly and the sealing ring completely fits into the groove provided.</p> <p>⇒ Correct</p>
	<p>Check whether the sealing ring perfectly fits on the connection port of the suction pipe and the suction pipe has been correctly introduced into the lid orifice provided for this.</p> <p>⇒ Correct</p>
	<p>Check whether the tube clamp of the drain has been correctly closed and the drain has been correctly attached to the drainage opening.</p> <p>⇒ Close the tube clamp; correctly attach the drain to the drainage opening.</p>
	<p>Damages to the collection container of the LipoCollector® 3 caused by</p> <ul style="list-style-type: none"> • improper processing to be recognized by cracks in the container or deformations; • indentations on the lid edge <p>can also result in an vacuum insufficiency. This can be recognized by bubble formation during liposuction.</p> <p>⇒ Replace the collection container</p>



Do not use the collection container any longer if it shows damages. Strictly adhere to the processing instructions.



Follow the instructions given in the user manual for the suction device used.

6.3. Watery lipoaspirate

If the collected lipoaspirate is still too watery after removal of excessive liquid (see section 4.4.2) this may be partly due to a clogged mesh filter.

Remove the clogging particles from the mesh filter by carefully scraping e.g. with a cannula. For this, open the orifice “EXTRACT“ beforehand and cautiously introduce the auxiliary instrument through this orifice into the collection container.

If the mesh filter is still blocked, we recommend using the water straw (REF 675020).



Fig. 6.1: Water straw

To remove excessive liquid from the LipoCollector® 3 by means of the water straw proceed as follows:

- (1) Pull the connection tubing off the connection port “SUCTION” and attach it to the hose connector of the water straw.
- (2) Pull the suction pipe out. Instead, push the water straw through this orifice into the LipoCollector® 3 until the container bottom.
- (3) Switch the suction unit on. By adjusting the vacuum setting you can control the suction speed. To ensure that only excessive liquid is removed, but not fat cells, we recommend working with the minimum vacuum.
- (4) Start suctioning by closing the bypass hole of the water straw.
- (5) Stop or finish suctioning by opening the bypass hole again.
- (6) After finishing suctioning, switch the suction unit off.

Furthermore, it is advisable to put the extraction syringe into a holding rack with the piston facing upwards and leave it there for about ten (10) minutes. During this time, the fat continues separating from the liquid due to its natural buoyancy. Afterwards, excessive liquid can be pushed out of the syringe, before the fat will be transferred into smaller syringes for further use.

7. Technical data

Dimensions (incl. foot ring):	Ø 150 mm x 245 mm
Weight (incl. foot ring):	3 kg
Maximum collection volume:	1000 ml
Device class acc. to Council Directive 93/42/EEC:	IIa
Approvals:	CE 0482
Ambient conditions for transport and storage:	<u>Single-use components:</u> To be stored at a temperature between 5°C and 35°C, protected from humidity and sun radiation <u>Reusable components:</u> To be stored protected from light, dust, humidity and extreme fluctuations in temperature

8. Accessories, spare parts and extras

Only original spare parts and accessories are allowed be used.

8.1. Accessories

Item	REF No.
Disposable set	670200
Extraction cannula 200 mm	US675010

8.2. Spare parts

Item	REF No.
Lid	US670020
Fixation ring	US650041
Basket	US670050
Suction pipe 700 ml	US670180
Suction pipe 1000 ml	670190
Collection container	676000
Foot ring	US653200
Separation pipe	US670030
Connection tubing with funnel, 3 m	1306.3000.10

8.3. Extras

Item	REF No.
Water straw	US675020
Syringe rack	US610300
BEAULI [®] infiltration cannulas	US655020, 655030, 655031
Luer-adapter	5206634

9. Liability, warranty and customer service

9.1. Liability and warranty

The LipoCollector® 3 and its accessories must be checked for defects and transport damage immediately upon receipt. Damages or defects in this regard can only be claimed if the seller or the carrier is notified without delay.

Human Med grants their customers a 24-month warranty for supplied devices in accordance with the company's General Terms and Conditions starting from the date of shipping.

The warranty covers the repair or replacement of all parts and components with defects provided that it is clearly verified that these have been caused by the manufacturer. No warranty will be assumed for any faults resulting from wear and tear in use, improper use and any damage caused intentionally or by gross negligence. Further claims, particularly claims for damages are excluded.

The manufacturer accepts no liability for damage and failures that arise from non-observance of the user manual.

Human Med expressly warns against modifying its products. Any modification exempts the Human Med AG from any liability.

9.2. Customer service

Do you have any questions concerning the equipment or instructions for use? If so, please contact either your distributor or the manufacturer directly, Human Med AG.

We will be glad to provide further assistance. You reach our customer service as follows:

Business hours: Weekly from Monday to Friday
From 08:00 to 16:30 CET

Postal address: Human Med AG
Wilhelm-Hennemann-Straße 9
19061 Schwerin/ Germany

Phone: +49 / (0)385 / 39570-0
Fax: +49 / (0)385 / 39570-10
Email: info@humanmed.com